

## Production of [ $^{18}\text{F}$ ] fluoride with a high-current two layer spherical gold target

M. Mirzaii<sup>1,2\*</sup>, H. Afarideh<sup>1</sup>, S.M. Haji-Saeid<sup>1</sup>, G.R. Aslani<sup>1</sup>, M.R. Ensaf<sup>1</sup>

<sup>1</sup>Nuclear Research Center for Agriculture and Medicine (NRCAM)

<sup>2</sup>Amir Kabir University of Technology

---

---

### ABSTRACT

**Background:** Fluoride-18 is the most widely used radioisotope for Positron Emission Tomography (PET). [ $^{18}\text{F}$ ] 2-fluoro- 2-deoxy D-glucose (FDG) has become a standard tool in the area of clinical research. The oxygen-18 enriched water is the most widely used target for the production of fluoride-18. The use of the nuclear reaction  $^{18}\text{O}(\text{p},\text{n})^{18}\text{F}$  has been found as the most effective method for the production of [ $^{18}\text{F}$ ] fluoride.

**Materials and methods:** Gold is a chemically resistant metal, which has been found wide application in the chemical industry where it is often used in corrosive environments at high temperature. It is also one of the highest thermal conductivity of metals. A two layer-spherical gold chamber design was chosen to obtain a maximum pressure stability under high beam currents. The target body is consisted of two chambers, internal chamber for internal cooling and external chamber for enriched water target.

**Results:** The target is irradiated with 28 MeV protons energy. The incident energy on the target chamber is 18 MeV. This target is operated without external over-pressure and has been tested for beam currents up to 60  $\mu\text{A}$ . The measured target yield is 2655 MBq/ $\mu\text{Ah}$ . There is found that saturation yield is 8.3 GBq/ $\mu\text{A}$  and shows 80% of theoretical yield.

**Conclusion:** It was observed that gold is a good material for the construction of the target chamber, and also the spherical chambers are the best construction to bearing high pressure under high-current beam condition up to 60  $\mu\text{A}$ . *Iran. J. Radiat. Res.; 2003; 1(2): 119 – 124.*

---

---

**Keywords:** Water target, [ $^{18}\text{F}$ ] fluor, FDG, (PET), high current.

### INTRODUCTION

The proton irradiation of oxygen-18 is one of the most appealing nuclear reaction for producing fluor-18. Increasing demand for the glucose analogue 2[ $^{18}\text{F}$ ]-2-deoxy- D- glucose (FDG) for Positron Emission tomography (PET) continues to challenge investigators to develop more efficient high and low pressure target systems

for production of tens Giga Bq; quantities of [ $^{18}\text{F}$ ] fluoride ion (Killboarn *et al.* 1984, Berridge and Tewson 1986, Wieland and Wolf 1983, Dejesus *et al.* 1986, Keikonen *et al.* 1986, Nickels *et al.* 1986, Vogt *et al.* 1986, Huszar and Weinreich 1985, Wieland *et al.* 1986, Iwata *et al.* 1987, Qaim *et al.* 1987, Solin *et al.* 1988, Mulholl and *et al.* 1989, Steinbach *et al.* 1990, Roberts *et al.* 1995, Van Brooklin *et al.* 1995, Berridge and Kyellstrom 1995, Zeisler *et al.* 1999, Hess *et al.* 2002, Zeisler *et al.* 2002, Helmeke *et al.* 2001, Berridge *et al.* 2002).

Many factors should be considered for a reliable target design. They include thickness of the window and cooling fluid layer for optimum

---

\* Corresponding author:

M. Mirzaii; Nuclear Research Center for Agriculture and Medicine (NRCAM)

P.O.Box: 31585-4395 Karaj-Iran. Fax: +98-261- 4411106.

E-mail: [mmirzaii@aeoi.org.ir](mailto:mmirzaii@aeoi.org.ir)

beam degradation, efficient cooling fluid for target chamber and window, and selection of suitable geometry and material for the target body. Most considerations have to be given to the heat transfer and chemical properties of the target body material. The fluorine [ $^{18}\text{F}$ ] is produced as nanogram quantities, which can react with the internal surfaces of the target chamber to form insoluble complexes, and the result is the reduction of the extracted yield of reactive fluoride ions.

The possible materials for the mentioned target chamber are silver and gold. Although silver shows the highest thermal conductivity of the elements, under the beam conditions it often forms colloids, which contaminates the solution and causes to trap fluoride ions (Zeisler *et al.* 2000). Gold has one of the highest thermal conductivity among metals, and also under beam conditions metal and inert, which is used in corrosive environment and condition.

Spherical construction is a choice to bear pressure and obtain a maximum pressure stability for a given wall thickness (Backer and Erabe 1998).

According to our calculations with SRIM code (Ziegler *et al.* 2000) a proton energy range at about 28 MeV is required to permit a reasonable production of [ $^{18}\text{F}$ ] fluor due to the aluminum and the gold windows, (The aluminum window is on the vacuum side and the gold window is on the target side), cooling fluid, and the target body degradation of cyclotron beam which is approximately 10 MeV, (Table 1). It is not feasible for babycyclotrons and other similar accelerators because of the wide range of energy.

## MATERIALS AND METHODS

### Target design

The target was constructed with two gold chambers, one inside another. Thus, special two-piece stamping die (male- female) for the manufacturing of two different diameters of gold hemispheres was supplied.

The hemispheres were deep drawn (forming the circular foil to give a hemisphere shape by

pressing and pulling) from circular gold foil (0.220 mm thickness, 28.3 mm and 17 mm in diameter for outer and inner hemispheres respectively) which were cut from an available sheet (gold alloy >95% gold, <5% Silver) using a manual press.

A hole was drilled into the center of each hemisphere and a small-bore silver tube of 80 mm length was inserted (1.5 mm o.d., 0.8 mm i.d. and 4 mm o.d., 3 mm i.d. for outer and inner spheres, respectively).

First of all the tubes were welded into the hemispheres and then the two pair hemispheres were welded together. Two chambers, consisting of internal cooling chamber and target chamber are approximately 12 mm and 20 mm in diameter, respectively. Figures 1 and 2 show pictures of the bare target and the target chamber with brass support and Swagelok<sup>TM</sup> fittings attached. A schematic of the developed target system is shown in Figure 3. Before loading the target with enriched water, nitrogen was purged through the target body and delivery line for about 10 minutes. This is done by rotating the Rheodyne<sup>TM</sup> valve to dispense position and opening the nitrogen supply valve. Then the target chamber rinsed with 20 ml absolute ethanol and after that do this by 20 ml of distilled water.

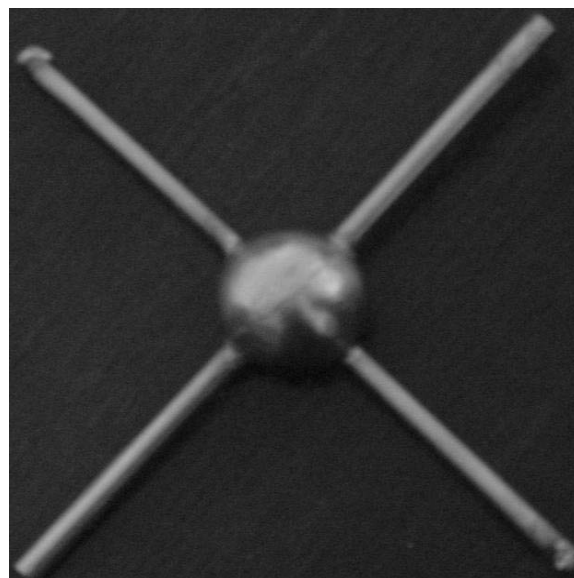
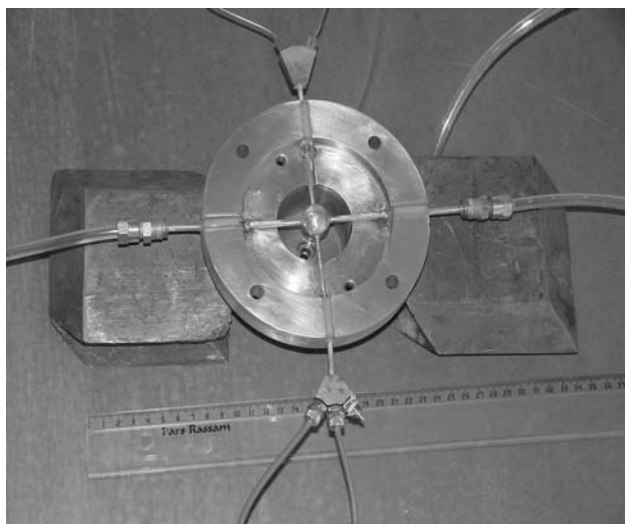

Figure 1. Picture of the bare two layer target.



**Figure 2.** Picture of the spherical gold target with brass holder and tubes for cooling and loading the target.

The target body is consisted of two chambers, internal chamber (a sphere with 12-mm in diameter) and external chamber (a sphere with 20-mm in diameter). In fact the internal chamber is the internal cooling system. In the target-cooling chamber water flow rate is 1.2 l/min at 2°C. The gap between the two spheres is 4-mm, which is sufficient to stop the 18 MeV protons beam inside the enriched water target (Table 1). The volume of the target chamber is approximately 2.8 ml. The external cooling water provides rapid cooling by water flow rate about 31/min at 2°C around the target chamber. So there is 4.2l/min of the cooling water flowing now. The aluminum window (Placed on the vacuum side, 0.3 mm thickness and about 22 mm in diameter) is designed as a hemisphere, so that half of the spherical chamber is placed inside, and it has a 1.3-mm gap for passing the cooled water between the window and the target chamber. The proton incident energy of 28 MeV is degraded to 18 MeV in the target, resulting in a production rate of 2655 MBq (71.76 mCi/ $\mu\text{A}\cdot\text{h}$ ). It is found that saturation yield is 9 GBq/ $\mu\text{A}$  and shows 80% of the theoretical yield.

#### Target operation

The two-layer gold sphere target is clamped on to the window holder by a brass support

piece, onto which the target water-cooling assembly (internal and external cooling) is connected. The target was filled with 2.8 ml of 18O- water (95%-18O) by means of an automated double three-way Rheodyne valve, which is powered by the compressed air at about 90 Psi.(Figure 4). The target chamber and Rheodyne valve were connected by PEEK tubes (200 mm in length, 1.6 mm o.d, 0.8 mm i.d).Test irradiations were performed on the Cyclone 30 of the Nuclear Research Center for Agriculture and Medicine of Iran with 28 MeV protons and 60  $\mu\text{A}$  of beam current.

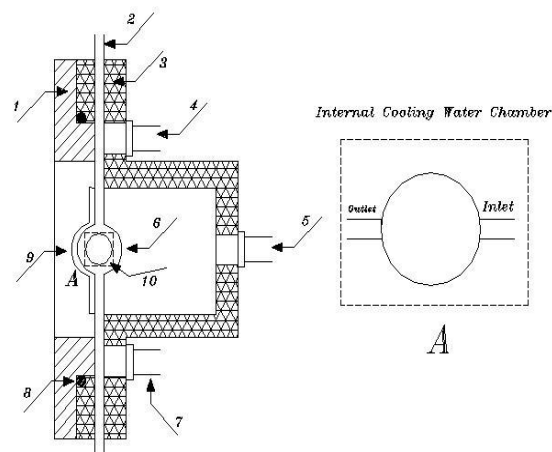

**Figure 3.** Schematic technical drawing of the target system.

(1) window holder (aluminum);(2) silver rod; (3) target holder (brass); (4) cooling water outlet ;(5) cooling water inlet;(6) target chamber (gold);(7) cooling water inlet; (8) O-rings(Viton);(9)vacuum window(aluminum,0.3mm); (10) internal cooling chamber (gold).

The target was cooled at a total water flow rate of 4.2 l/min. After bombardment the Rheodyne valve was actuated and opened. Then, the target water was transferred through a 20 m Teflon tube (PTFE, 1.6 mm o.d., 0.8 mm i.d.) to the hot cell by nitrogen pressure (0.8 bar).

## RESULTS AND DISCUSSION

The pressure stability  $P_{\text{max}}$  (bar) of an ideal spherical shell can be estimated using the

**Table 1.** Calculated estimate of energy loss in different parts of target assembly.

Energy (MeV)	Window Thickness (Al)	Cooling water Thickness	Wall Thickness of the Target Chamber	The Target Thickness
		0.3 mm	1.5 mm	0.25 mm
$E_{in}$	27.8	26.5	23.0	18.0
$E_{out}$	26.5	23.0	18.0	1.0
Energy loss( $\Delta E$ )	1.5	3.5	5.0	17.0

equation (Becker and Erbe 1998, Zeisler and Becker2000):

$$P_{max} = 4 h \times \sigma / d$$

Where h is the wall thickness (mm); d is the diameter (mm) of the sphere chamber, and  $\sigma$  is the tensile strength (bar).

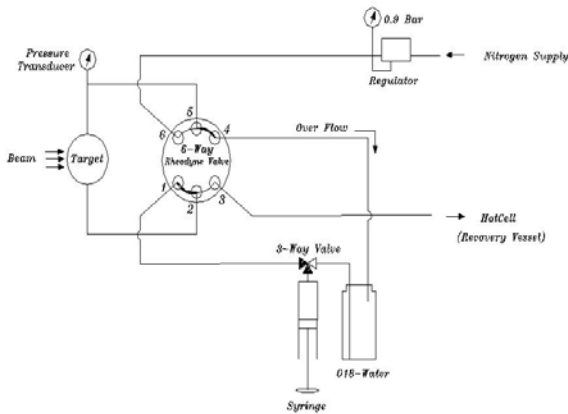
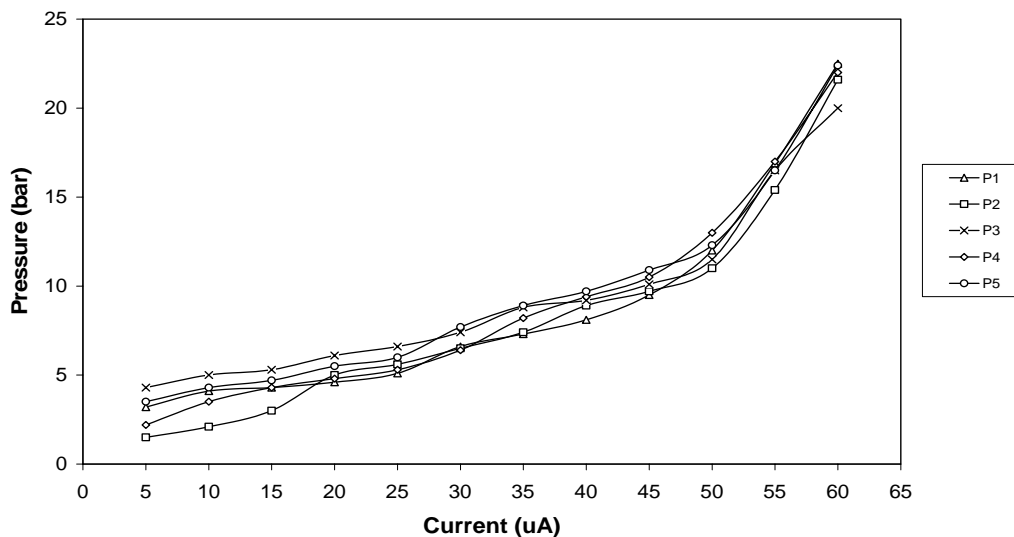

**Figure 4.** Schematic representation of the unit for remotely filling the  $^{18}\text{O}$ -enriched water target at the NRCAM cyclotron unit.

With regard to the tensile strength of the soft gold (2200 bar) and the chamber dimensions specified above, the target can withstand an internal pressure of approximately 100 bar.

Although we know that the equation does not take into account any welded tubes and situations of the material at elevated temperatures, the predicted stability of the target chamber exceeds the regular operating pressure by more than one magnitude order.

The measurement of the target pressure is one of the key factors for the assessment of the correct target filling and the irradiation conditions. Kulite (Kulite conductors Ltd) pressure transducer of XTM<sup>TM</sup>-190 was used to measure the target pressure. The pressure behavior of the target during the irradiation is shown in Figure 5. At 60  $\mu\text{A}$ , the observed pressure was 22.5 bar. Figure 6 shows cumulative energy deposition as a function of depth for the 18 MeV protons incident on the



**Figure 5.** Pressure in the target chamber Vs. beam current (18MeV protons).

$^{18}\text{O}$ -water. As shown in figure 6 almost 50% of the beam energy is deposited in the last 1 mm of the target using SRIM (Ziegler *et al.* 2000) calculations which is in accordance with the literature (Gonzales *et al.* 1997). Since, the maximum heat is produced near the center of spherical chamber, according to this effect we decided to design and construct an internal cooling system, which included a gold sphere with 12-mm diameter inside the target chamber. High-pressure  $^{18}\text{O}$ -water targets present an attractive alternative for the fast and reliable production of [ $^{18}\text{F}$ ] fluoride in large amounts.

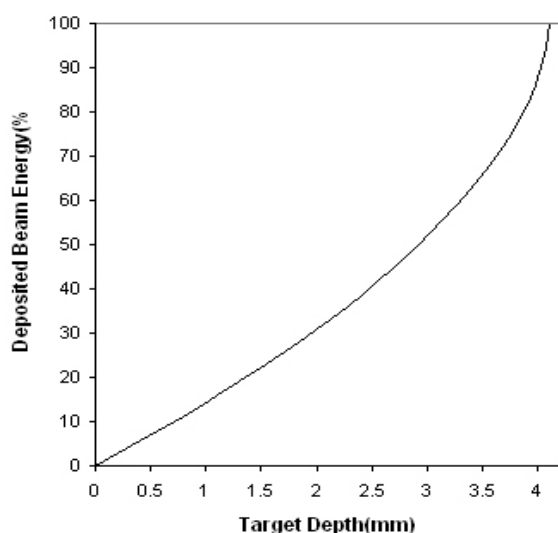

**Figure 6.** Calculated estimate of energy deposited by the beam as percentage of total for 18MeV protons incident to the  $^{18}\text{O}$ -water target.

## CONCLUSION

By observing at irradiation results, we have noticed that our designed target (Figures 2 and 3) can easily withstand 60  $\mu\text{A}$  proton beams. Although, the maximum current incident on our target was 60  $\mu\text{A}$ , we expect that it can surely withstand current of up to 80  $\mu\text{A}$ . This as compared with the previously designed targets that could be withstand about 50  $\mu\text{A}$  proton beam is considered as a break through.

With employing our designed target as compared to the routinely used target (The target is available in 1.7 ml real volume, designed and

manufacturing by I.B.A company-Belgium) we succeeded to increase our productions up to 5 times as much, which in turn reduced our irradiation time up to 5 times. In fact this means reduction of production costs.

## ACKNOWLEDGEMENT

*Our thanks to the personnel of the Cyclotron Cyclone 30, N. Shadanpoor and P. Roshanfarzad for performing the irradiations. We also gratefully acknowledge our engineer A. Rostamian, and technicians; A. Rajamand, F. Safari, M. Agaii and E. Einali for technical support of the target body system.*

## REFERENCES

- Backer D.W., Erbe D. (1998). A new high current spherical target design for  $^{18}\text{O}(\text{p},\text{n})^{18}\text{F}$  with 18 MeV protons. In: Proc.7<sup>th</sup> Workshop on Targetry and Target Chemistry, Heidelberg 1997, pp. 268-269.
- Berridge M.S., Tewson T.J. (1986). Effects of target design on the production and utilization of [ $^{18}\text{F}$ ] fluoride from [ $^{18}\text{O}$ ] water. *J. Labelled Compd. Radiopharm.*, **23**: 1177-1178.
- Berridge M.S., Kjellstrom R. (1995). Fluorine-18 production: new designs for O-18 water targets. *J. Labelled Compd. Radiopharm.*, **26**: 188-189.
- DeJesus O.T., Martin J.A., Yasillo N.J., Gatley S.J., Cooper M.D. (1986). [ $^{18}\text{F}$ ] Fluoride from a small cyclotron. *Appl. Radiat. Isot.*, **37**: 397-401.
- Gonzales Carlos E. Lepera and Barry Dembowski (1997). Production of [ $^{18}\text{F}$ ] fluoride with a high-pressure disposable [ $^{18}\text{O}$ ] water target. *Appl. Radiat. Isot.*, **48**: 613-617.
- Helmeke H.J., Tharms, W.H.knapp (2001). A water target with beam sweep for routine fluorine-18 production. *Appl. Radiat. Isot.*, **54**: 753-759.
- Hess, E. G. Blessing, H.H. Coenen, S.M. Qaim (2000). Improved target system for production of high purity [ $^{18}\text{F}$ ] fluoride via the  $^{18}\text{O}(\text{p},\text{n})^{18}\text{F}$  reaction. *Appl. Radiat. Isot.*, **52**: 1431-1440.
- Huszar I., Weinreich R. (1985). Production of  $^{18}\text{F}$  with an  $^{18}\text{O}$ -enriched water target. *J. Radioanal. Nucl. Chem. Lett.*, **93**: 349-354.
- Iwata R. Ido.T., Brady F., Takahashi T., Ujiie A. (1987). [ $^{18}\text{F}$ ]Fluoride production with a

- circulating [ $^{18}\text{O}$ ] water target. *Appl. Radiat. Isot.*, **11**: 979-984.
- Keikonen J., Fontell A., Kaireto A.L. (1986). Effective small volume [ $^{18}\text{O}$ ]water target for the production of [ $^{18}\text{F}$ ]Fluoride. *Appl. Radiat. Isot.*, **37**: 631-632.
- Kilbourn M.R., Hood J.T., Welch M.J. (1984). A simple  $^{18}\text{O}$  water target or  $^{18}\text{F}$  production. *Int. J. Appl. Radiat. Isot.*, **35**: 599-602.
- Kulit measuring pressure sensor (Type: XTL-190M 0-35 bar), Kulit conductors Ltd. Kulit House, stroudly road, Kingsland Business Park, GB-Basingstoke, Hampshire RG24 8UG.
- Mulholland G.K., Hichwa R.D., Kilbourn M.R., Moskwa J. (1989). A reliable water target for fluorine-18 production at high beam currents. *J. Labelled Compd. Radiopharm.*, **26**: 192-193.
- Nickles R.J., Gatley S.J., Votaw J.R., Kornguth M.L. (1986). Production of reactive fluorine-18. *Appl. Radiat. Isot.*, **37**: 649-661.
- Qaim S.M., Blessing G., Stocklin G. (1987). Routinely used cyclotron targets for radioisotope production at KFA Julich. In: Proc. 2<sup>nd</sup> Workshop on Targetry and Target Chemistry, Heidelberg 1985, pp. 50-57.
- Roberts A.D., Daniel L.C., Nickles R.J. (1995). A high power target for the production of [ $^{18}\text{F}$ ] fluoride. *Nucl. Inst. Meth. Phys. Res.*, **B 99**: 797-799.
- Solin O., Bergman J., Haaparanta M., Reissel A. (1988). Production of  $^{18}\text{F}$  from water targets. *Appl. Radiat. Isot.*, **39**: 1065-1071.
- Steinbach J., Guenther K., Loesel E., Grunwald G., Mikecz P., Ando L., Szeleceenyi F., Beyer G.J. (1990). Temperature course in small volume [ $^{18}\text{O}$ ] water targets for [ $^{18}\text{F}$ ]F<sup>-</sup> production. *Appl. Radiat. Isot.*, **41**: 753-756.
- Van Brocklin H., Padgett H., Alvord C., Schimdt D., Bida G. (1995). High pressure H<sub>2</sub><sup>18</sup>O target for the production of [ $^{18}\text{F}$ ] fluoride ion. In: Emran, A.M. (Ed.), Chemists View of Imaging Centers. Plenum press, New York, pp. 329-338.
- Vogt M., Huszar I., Argentini M., Oehninger H., Weinreich R. (1986). Improved production of [ $^{18}\text{F}$ ] fluoride via the [ $^{18}\text{O}$ ]H<sub>2</sub>O(p,n)  $^{18}\text{F}$  reaction for no-carrier-added nucleophilic syntheses. *Appl. Radiat. Isot.*, **37**: 448-449.
- Wieland B.W., Wolf A.P. (1983). Large-scale production and recovery of aqueous [ $^{18}\text{F}$ ] fluoride using proton bombardment of small-volume [ $^{18}\text{O}$ ]water target. *J. Nucl. Med.*, **34**: 122-127.
- Zeisler S.K., Becker D.W., Pavan R.A. (2000). A water-cooled spherical niobium target for the production of [ $^{18}\text{F}$ ] fluoride. *Appl. Radiat. Isot.*, **53**: 449-453.
- Ziegler J.F., Biersack J.P., Littmark U. (2000). The code of SRIM "The Stopping and Range of Ions in Matter", version 2000.xx.