

Monte carlo simulation of varian clinac iX 10 MV photon beam for small field dosimetry

S. Yani^{1*}, M.F. Rhani², R.C.X. Soh³, F.Haryanto⁴, I. Arif⁵

¹Department of Physics, Faculty of Mathematics and Natural Sciences, Institute Technology Bandung, Indonesia

²Department of Radiation Oncology, National University Cancer Institute Singapore, Singapore

³School of Physical and Mathematical Sciences, Nanyang Technological University, Singapore

⁴Department of Physics, Faculty of Mathematics and Natural Sciences, Institute Technology Bandung, Indonesia

⁵Department of Physics, Faculty of Mathematics and Natural Sciences, Institute Technology Bandung, Indonesia

ABSTRACT

Background: The lack of lateral electronic disequilibrium (LED) becomes a main problem in small field. This factor affects the dose in target volume cannot predict correctly. In addition, utilization of high-energy linear accelerator (10 MV) can emit some unwanted particles (electron contamination). Therefore, the aim of this study was to characterize head linear accelerator (linac) Varian Clinac iX 10 MV photon beam for square small field size (1×1, 2×2, 3×3, 4×4 and 5×5 cm²) using Monte Carlo (MC) simulation.

Materials and Methods: The commissioning process for this linac, has been conducted for field size 6×6, 10×10 and 20×20 cm² by comparing the measurement and MC simulation data. Head linac simulation was performed with BEAMnrc and dose calculation with DOSXYZnrc. The phase space (phsp) data from BEAMnrc was analyzed using BEAMDP to get the particles information in scoring plane. **Results and Discussion:** The scatter angle of particles depends on the field size. This factor affects the penumbra width in water phantom. On the other hand, PDD data show that the depth of maximum dose and penumbra width in small field shifted correspond with the number of scatter particle. The difference of relative output factor between measurement and MC results were found less than 2%. However, the 2% difference was still acceptable in photon beam dosimetry. **Conclusion:** From this simulation, the electron contamination give contribution in surface dose of water phantom about 13.0581% and less than 1% for field size 10×10 cm² and small field size, respectively.

Keywords: Photon beam, Monte Carlo, small field dosimetry.

► Original article

*Corresponding authors:

Dr. Sitti Yani,

Fax: +62 852 11181223

E-mail: sitti.yani@itb.ac.id

Revised: June 2016

Accepted: Aug. 2016

Int. J. Radiat. Res., July 2017;
15(3): 275-282

DOI: 10.18869/acadpub.ijrr.15.3.275

INTRODUCTION

Nowadays, radiotherapy becomes the major treatment options in cancer treatment in many countries including Indonesia. The survival ratio of patients who used this kind of treatment have been increasing in latest year. This treatment is often applied to the oncology patient in combination with surgery and chemotherapy. However, in order to reduce the radiation dose to the healthy tissues and maximizing the radiation dose to the tumor, every parameter in

radiotherapy treatment has to optimize many parameters. The accurate dosimetry related to some parameters such as organ at risk (OAR) and target volume, beam arrangement and modulation, particles contamination (electron and neutron), inhomogeneity correction etc. The electron contamination produced from linear accelerator photon beam give big contribution to this dose calculation accurately especially on the phantom surface and build-up region ⁽¹⁻³⁾. This study have been reported by many researchers using direct measurement ^(3,4).

5), analytical (3) and MC method /. The electron gave contribution around 30% on the water phantom surface for large field size and high-energy linac (4-6). Mesbahi et al. (2007) compared the electron contamination in Varian 21EX and Elekta SL-25 linacs for field size 10×10 and 20×20 cm². The electron contamination energy spectra showed similar pattern and fluence for both linacs (6). Allahverdi et al. (2011) found that the maximum electron contamination dose on surface phantom for 18 MV photon beam was around 38.8% for field size 40×40 cm² (7). Yani et al. (2014) reported that the electron contamination dose has the big contribution in beam axis for field size 6×6, 10×10 and 20×20 cm² around 16, 40 and 54%, respectively in the 6 MV photon beam (8). But most of research only concern on electron contamination for large field size (4-8).

Nowadays, some radiotherapy technique such as intensity modulated radiotherapy (IMRT) (9-11) and volumetric modulated arc therapy (VMAT) (12, 13) utilize small field dosimetry to obtain the better outcome of treatment. The lack of lateral electronic disequilibrium (LED) in high-energy photon beam becomes a main problem in small field. This factor affects the dose in OAR and target volume cannot predict correctly (14-16).

The MC method is widely accepted as the most accurate and rigorous technique in simulating radiation transport and scoring energy deposition in homogenous and inhomogenous material (17-21). One particular of MC code is EGSnrc commonly used to model ionization radiations in many medical physics application. The MC method can accurately account for variations in density and atomic number and can handle complex geometry but

requires a long computational time (22-24).

Therefore, the aim of this study was to characterize head linac Varian Clinac iX 10 MV photon beam for small field size (1×1, 2×2, 3×3, 4×4 and 5×5 cm²) using Monte Carlo simulation.

MATERIALS AND METHODS

The electron gamma shower *EGSnrc* MC Code was developed by the National Research Council of Canada (NRC) (25). *BEAMnrc* and *DOSXYZnrc*, based on *EGSnrc* code are used to perform simulation of radiation transport. *BEAMnrc* was used to build the head linear accelerator with component module provided. On the other hand, *DOSXYZnrc* was used to simulate dose in water phantom or phantom form CT data.

EGSnrc-based *BEAMnrc* code was used to build the linac model and generate the phase space files in the desired position. The geometric and material description of linac head components including target, primary collimator, vacuum window, flattening filter (FF), ionization chamber, secondary collimator (JAWS X and Y) and multileaf collimator (MLC) were simulated based on manufacturer (Varian) information. The detail of parameter used in this simulation as described in table 1. To reduce the simulation time, the simulation was divided into two step: patient-independent component (target, primary collimator, vacuum window, FF, ionization chamber) and patient-dependent component (JAWS and MLC). There are two phsp files e.g. scored after ionization chamber and after MLC. In the other hand, the cross section data used was provided by *EGSnrc* 521icru.pegs4dat (26).

Table 1. Details of CMs parameters.

CMs name	Distance from reference plane (cm)	Number of layer	Materials	Density (g/cm ³)
Target and primary collimator	0	6	Copper Tungsten	8.96and 19.25
Vacuum window	8.66	1	Beryllium	1.85
Flattening filter	11.932	34	Copper	8.96
Ion Chamber	15.05	20	Kapton and Air	1.42and 0.0012
JAWS Y	27.88	1	Blok Tungsten	19.25
JAWS X	36.63	1	Blok Tungsten	19.25
MLC	48.185	2	Tungsten	19.25

Phsp files containing information of the types, energies and orientations of all particles in a scoring plane were generated using the *BEAMnrc* code according to the model of a Varian Trilogy Clinac iX 10 MV photon beam. The phsp file can be characterized to find out the characteristic of a photon beam in the linac modelled. The particle fluence, spectral distribution, angular distribution and mean energy can be reconstructed from phsp file generated for each field sizes. A utility program *BEAMDP* (BEAM Data Processor) can be used to analyze the phase space data. Using this program, the photon spectral distribution of particle in phsp files scored in scoring plane can be obtained in *X* or *Y* direction. In this simulation, we used rectangular field with rectangular bins in *Y* direction with 200 number of bins without LATCH. X_{min} , X_{max} , Y_{min} and Y_{max} of rectangular fields were -15 cm, 15 cm, -15 cm and -15 cm, respectively. The graph type was histogram and planar graph.

The number of incident particles arranged related to the capacity of phsp file desired. For example: to achieve the capacity of phsp file for field size $1 \times 1 \text{ cm}^2$, number of incident particle from source not less than 10×10^{10} particles. The number of incident particles will decrease if the larger field width was simulated. The length of simulation time in MC depended on the amount of incident particles used. The simulation time will increase with the rise of number of incident particles. In addition, number of particles also affects the statistical uncertainty. The large amount of particles can reduce this uncertainty in MC simulation.

To verify the linac model and used parameters, the commissioning procedure for this linac has been done by Ramdani for field size 6×6 , 10×10 and $20 \times 20 \text{ cm}^2$ (27). The dose profile and PDD was comparing with measurements data from Tan Tock Seng Hospital (TTSH) Singapore using water phantom with dimension $40 \times 40 \times 40 \text{ cm}^3$. The results of this process, we found that the energy of incident electron was 10.3 MeV and full width at half maximum (FWHM) was 0.1 cm. These parameters were used to simulate small field size (1×1 , 2×2 , 3×3 , 4×4 and $5 \times 5 \text{ cm}^2$). The

Tungsten MLC with rounded shape was the defined field width. In this study, the air between linear accelerator and water phantom was simulated by insert a SLAB with vacuum material.

Similar to *BEAMnrc* input, the cross section data used in *DOSXYZnrc* was provided by EGSnrc 521icru.pegs4dat. All the *DOSXYZnrc* input parameters, including EGSnrc parameters, can be incorporated in an input file with extension *.egsinp; and it was advantageous to use the GUI program to facilitate the data input. The radiation source location and directions can be specified in the input file (Source 2: Full phase-space source file). Phsp file scored after MLC with SSD 100 cm was used in this simulation. Also, the default EGSnrc particle transport parameters selected by *DOSXYZnrc* are employed (28). The PDD, profile dose and output factors (OFs) were calculated in this simulation. The dose profiles and OFs scored in 10 cm depth for each field size. The relative OFs from MC simulation were evaluated and compared with the measured values obtained from Semiflex 2801 (PTW Freiburg, Germany).

In some condition for better results, we used voxel with various sizes both of PDDs and dose profiles, for example in the build-up region voxels was smaller than voxels in the tail region (figure 1). The number of voxels increased with the field width. Based on our previous study, we found that the appropriate arrangement and dimension of voxel affect the results of simulation (29). In addition, a huge number of particles needed to get the statistical uncertainty not more than 2% in this MC simulation. This uncertainty recorded in the end of simulation.

These simulations was run on parallel computing INTEL Core i7 processor with 8 cores with 3 GB RAM.

RESULTS AND DISCUSSION

Figure 2 shows the PDD and dose profile for field size $10 \times 10 \text{ cm}^2$. The capacity of phsp file after MLC scored in SSD 100 cm was 2.1 GB. The number of incident particles from original sources, number of particles in phsp files,

number of photon and electron was 2.29×10^9 , 76714199, 76371504 and 342695, respectively. Most of the electrons in the phsp file have energy around 0.5 MeV with electron range 0.164 cm. The electron gave contribution in surface dose of water phantom about 13.0581%.

Table 2 shows information of particles stored in phase space file for various small field size. Every field size have the same capacity about 1 GB. The number of particles in phsp files was divided into incident particles from original

source, number of particles in phsp files, number of photon and electron. The number of particles went up by the increasing of field width. The numbers of incident particles from original source has risen considerably the field sizes. From the table, number of photon climbed to approximately around 55106 photon from field 1 and 2 then rose dramatically by 3283203 photon from field 2 and 3 and then decrease by 785612 photon. Overall, the number of electron has changed for all of field size.

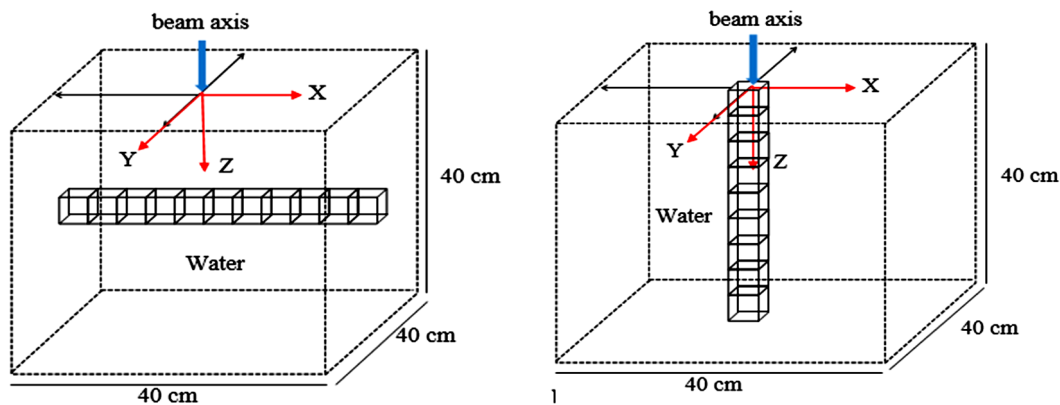

Figure 1. Phantom design (a) dose profile and (b) PDD.

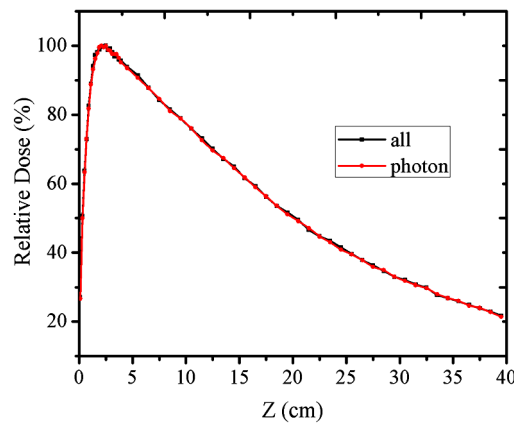

Figure 2. Comparison of PDD curve for all particle and photons for field size $10 \times 10 \text{ cm}^2$ SSD 100 cm in water phantom.

Table 2. Detail information of phsp file for various field size

Field sizes	Capacity (GB)	Number of particles			
		Incident particles from original source	Number of particle in phsp file	Photon	Electron
1x1	1	$>10^{10}$	36372129	36090902	281227
2x2	1	$>10^{10}$	36462364	36146008	316356
3x3	1	$>10^{10}$	39698347	39429211	269136
4x4	1	7×10^{10}	38729749	38643599	86150
5x5	1	4×10^{10}	42000471	41745232	255239

Figure 3(a) below shows the fluence of particles in phsp file for field size 1x1, 2x2, 3x3, 4x4 and 5x5 cm² (different graph color related with the field size). This fluence profile was used to confirm the field width. Profile was increased in the field and dropped dramatically in out of field region. All of the fluence are normalized with the maximum fluence for each field size. And figure 3(b) shows the mean energy of linac. This figure shows the geometry of flattening filter. The mean energy of particles peaked at inside of field and decline dramatically in the edge of field. And then was increasing slowly in the off-axis distance. The mean energy of particles shows the same trends for all of field size.

The beam hardening effects of the flattening filter (FF) can be observed from figure 3(b); The bremsstrahlung photon produced in target have been flatten by flattening filter, so the mean energy of particles in scoring plane remains same. The FF absorbs more low energy photons than high energy photons as the photon

attenuation coefficient decreases with increasing photon energy. The material of FF is Copper (density 8.96 gr/cm³ and thickness 0.508 cm). The FF with atomic number 30 can reduce the small energy of photon.

Figure 3(c) shows the spectral distribution and angular distribution of particles in phsp files. In calculating the photon spectrums, all photons passing through the corresponding scoring planes would be counted irrespective of their moving directions and locations on the planes. The particles in phsp file dominated photon with energy 0.5 MeV. This study was consistent with another study by Allahverdi *et al.* (2011)⁽⁵⁾. The maximum energy of particles is 10.285 MeV and the minimum energy 0.010 MeV. The scatter angle of particles depends on the field size. This factor affects the penumbra width in water phantom. The maximum scatter angle were 0.45°, 0.675°, 0.9°, 1.125°, and 1.35° for field size 1x1, 2x2, 3x3, 4x4 and 5x5 cm², respectively.

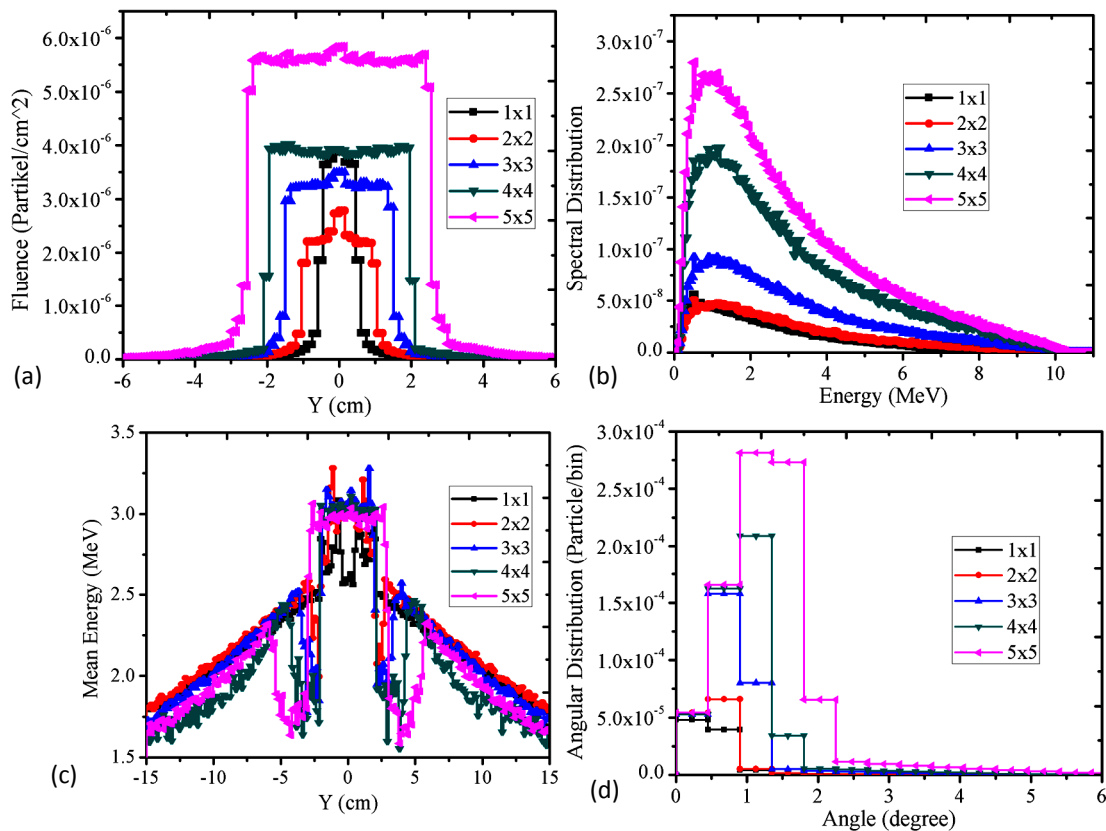

Figure 3. (a) Fluence (b) Spectral distribution (c) Mean energy and (d) Angular distribution of all particle at the phantom surface (defined at SSD = 100 cm and incident electron energy 10.3 MeV) inside the field sizes 1x1, 2x2, 3x3, 4x4 and 5x5 cm².

The 3d dose data from DOSXYZnrc analyzed using STATDOSE in direction Y and Z for dose profile and PDD, respectively. All the profile dose were normalized to the value of maximum dose and scored at depth 10 cm in water phantom (figure 4a). The statistical uncertainty for all of the simulations was less than 0.1 %. The penumbra width (region at the edge of field size which dose rate changed rapidly from 80% to 20%) for all small field size was around 0.4 – 0.6 cm. It is important to point out that the depth with dose maximum (D^{max}) for PDD curve little bit has shifted (figure 4b). For the smallest field size 1x1 cm², it was found to have a maximum depth of 2.7 cm, whereas for the largest field size 5x5 cm², the depth has increased to 2.1 cm. The shift in the maximum depth, correspond with the number of scatter particle. This results were in line with another study reported by Biggs and Ling (1979) (7).

These particles scattered with the largest angle and affected the penumbra width and D^{max} . On the other hand, the electron contamination dose was less than 1% for each field size.

Figure 5 shows compared between the measurement data and MC simulation of OFs for small field size. The OFs scored in 10 cm depth with the same condition (measurement and simulation) and normalized with square field 10x10 cm². The relative output factor, the measurement results have been compared with the MC results where the differences were found to be less than 2%. Charles et al. (2014) and Benmakhlouf et al. (2014) reported the same results that the discrepancies OFs between measurements and MC simulation especially for the small field size was affected by detector selections. However, the 2% difference was still acceptable in photon beam dosimetry (30, 31).

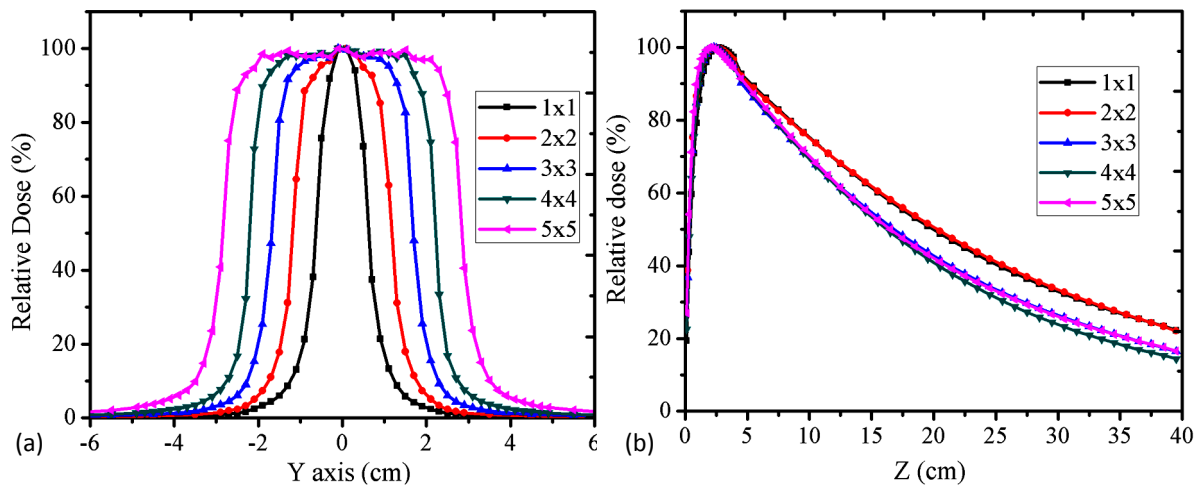

Figure 4. Normalized (a) percent depth dose and (b) profile dose curve for all particle for varied field sizes (defined at SSD = 100 cm and incident electron energy 10.3 MeV).

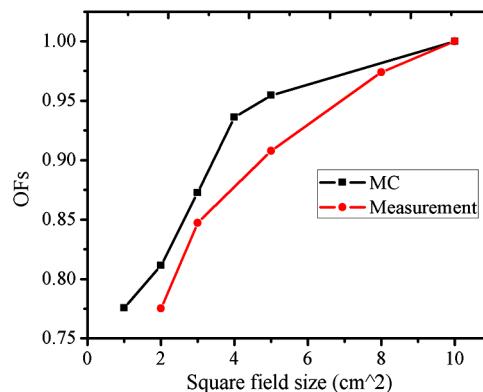

Figure 5. Comparison of OFs between MC simulation and measurement data for square field size 1x1, 2x2, 3x3, 4x4 and 5x5 cm².

CONCLUSION

This study demonstrated the accuracy of the Monte Carlo method in simulating the radiation transport in 10 MV photon beam. From this simulation, we found that the electron contamination give contribution in surface dose of water phantom about 13.0581% and less than 1% for field size 10×10 cm² and small field size, respectively. In addition, the depth with dose maximum (D_{max}) for PDD curve little bit shifted for small field size.

ACKNOWLEDGEMENTS

We are grateful to Tan Tock Seng Hospital, Singapore for the PDD, dose profile data (commissioning process) and OFs for the Varian Trilogy Clinac iX 10 MV photon beam. This study was fully supported by Penelitian Kerjasama Luar Negeri dan Publikasi Internasional Dikti (077/SP2H/PL/LT/II/2016) and Hibah Penelitian Disertasi Doktor, Ministry of Education Indonesia 2016.

Conflicts of interest: Declared none.

REFERENCES

- Ahnesjo A and Aspradakis M M (1999) Dose calculations for external photon beams in radiotherapy. *Phys Med Biol*, **44**.
- Mataras G, Kappas C and Lovelock DM (2001) A Monte Carlo approach to electron contamination sources in the Saturne-25 and -41. *Phys Med Biol*, **46**: 2435-46.
- Medina AL, Terron JA, Ruiz DP and Carrion MC (2005) Characterization of electron contamination in megavoltage photon beams. *Med Phys*, **32**: 1281-92.
- Sjögren and M Karlsson (1996) Electron contamination in clinical high energy photon beams. *Med Phys*, **23**: 1873-81.
- Allahverdi M, Zabihzadeh M, Ay MR, Mahdavi SR, Shahriari M, Mesbahi A and Alijanzadeh H (2011) Monte Carlo estimation of electron contamination in A 18 MV clinical photon beam. *Int J Radiat Res*, **9(1)**: 15-28.
- Mesbahi A, Mehnati P and Keshtkar A (2007) A comparative Monte Carlo study on 6 MV photon beam characteristics of Varian 21EX and Elekta SL-25 linacs. *Int J Radiant Res*, **5**: 23-30.
- Biggs J and Ling CC (1979) Electrons as the cause of the observed dmax shift with field size in high energy photon beams. *Med Phys*, **6**: 291-5.
- Yani S, Dirgayussa IGE, Pratama D, Rhani MF, Haryanto F, Arif I (2014) Determination the electron contamination from the head of Varian Clinac iX 6 MV photon beam using Monte Carlo simulation. Proceedings of The 14th AOCMP and 12th SEACOMP; 10-12 October 2014 Ho Chi Minh City, Vietnam.
- Stapleton S, Zavgorodni S, Popescu IA and Beckham WA (2004) Implementation of random set-up errors in Monte Carlo calculated dynamic IMRT treatment plans. *Phys Med Biol*, **50**: 429-39.
- Lee J, Park J, Chung J, Park J, Choe B, Suh T, Lee D, Hong S, Kang M and Choi K (2009) Inverse IMRT verification of the dose distribution for intensity modulated radiation therapy patient-specific quality assurance using dynamic MLC log files. *Journal of the Korean Physical Society*, **55(4)**: 1649-56.
- Luo W, Li J, Price Jr RA, Chen L, Yang J, Fan J, Chen Z, McNeeley S, Xu X, Ma C (2009) Monte Carlo based IMRT dose verification using MLC log files and R/V outputs. *Medical Physics*, **33**: 2557-64.
- Teke T, Bergman AM, Kwa W, Gill B, Duzenli C and Popescu IA (2010) Monte Carlo based, patient-specific RapidArc QA using Linac log files. *Medical Physics*, **37**: 116-23.
- Boylan CJ, Aitkenhead AH, Rowbottom CG, Mackay RI (2013) Simulation of realistic linac motion improves the accuracy of a Monte Carlo based VMAT plan QA system. *Radiotherapy and Oncology*, **109**: 377-383.
- Fippel M, Haryanto F, Dohm O and Nusslin F (2003) A virtual photon energy fluence model for Monte Carlo dose calculation. *Med Phys*, **30(3)**: 301-11.
- Charles PH, Cranmer-Sargison G, Thwaites DI, Crowe SB, Kairn T, Knight RT, Kenny J, Langton CM, Trapp JV (2014) A practical and theoretical definition of very small field size for radiotherapy output. *Medical Physics*, **41(40)**: 041707.
- Benmakhlof H, Sempau J, Andreo P (2014) Output correction factors for nine small field detectors in 6 MV radiation therapy photon beams: A PENELOPE Monte Carlo study. *Medical Physics*, **41**: 041711.
- Vazquez-Quino LA, Massingill B, Shi C, Gutierrez A, Esquivel C, Eng T, Papanikolaou N, Stathakis S (2012) Monte Carlo modeling of a Novalis TX Varian 6 MV with HD-120 multileaf collimator. *Journal of Applied Clinical Medical Physics*, **13(5)**: 300-13.
- Keall PJ, Siebers JV, Libby B, Mohan R (2003) Determining the incident electron fluence for Monte Carlo-based photon treatment planning using a standard measured data set. *Med Phys*, **30(4)**: 574-82.
- Mesbahi A (2006) Development a simple point source model for Elekta SL-25 linear accelerator using MCNP4C Monte Carlo code. *Iran J Radiat Res*, **4(1)**: 7-14.
- Sempau J, Sanchez-Reyes A, Salvat F, Tahar HO, Jiang SB, Fernandez-Varea JM (2001) Monte Carlo simulation of

- electron beams from an accelerator head using PENELOPE. *Phys Med Biol*, **46**: 1163–86.
21. Rassiah-Szegedi P, Salter BJ, Fuller CD, Blough M, Papanikolaou N and Fuss M (2006) Monte Carlo characterization of target doses in stereotactic body radiation therapy (SBRT). *Acta Oncologica*, **45**: 989-94.
 22. Jabbari K, Anvar HS, Tavakoli MB, Amouheidari A (2013) Monte carlo simulation of siemens oncor linear accelerator with BEAMnrc and DOSXYZnrc code. *Journal of Medical Signals & Sensors*, **3(3)**: 172-79.
 23. Lobo J and Popescu IA (2010) Two new DOSXYZnrc sources for 4D Monte Carlo simulations of continuously variable beam configurations, with applications to RapidArc, VMAT, TomoTherapy and CyberKnife. *Phys Med Biol*, **55**: 4431–43.
 24. Praveenkumar RD, Santhosh KP, Augustine A (2013) Monte Carlo Simulation of a Theratron Elite100 Telecobalt machine using BEAMnrc code. *IJERA*, **3(2)**: 1574-83.
 25. Kawrakow I and Rogers DWO (2000) The EGSnrc Code System: Monte Carlo Simulation of Electron and Photon Transport. National Research Council of Canada, Ottawa
 26. Rogers DWO, Walters B, Kawrakow I (2011) BEAMnrc. User's Manual. National Research Council Canada, Ottawa.
 27. Ramdani R, Yani S, Rhani MF, Arif I and Haryanto F (2015) Commissioning Linear Accelerator Varian Clinac iX Foton Beam 10 MV Menggunakan Simulasi Monte Carlo EGSnrc Code System. In Wungu TDK, Pramuditya S, editors. Proceedings of Simposium Nasional Inovasi dan Pembelajaran Sains 2015; 8-9 Juni 2015; Bandung, Indonesia: SNIPS Proceedings.
 28. Walters BRB, Kawrakow I, Rogers DWO (2011) DOSXYZnrc Users Manual. National Research Council Canada, Ottawa.
 29. Yani S, Dirgayussa IGE, Rhani MF, Haryanto F, Arif I (2015) The effect of voxel size on dose distribution in Varian Clinac iX 6 MV photon beam using Monte Carlo simulation. In Purqon A, Pramuditya S, editors. Proceedings of The 5th International Conference on Mathematics and Natural Sciences (ICMNS); 2-3 November 2014; Bandung, Indonesia: AIP Conference Proceedings; 2015. 1677 040002.
 30. Charles PH, Cranmer-Sargison G, Thwaites DI, Crowe SB, Kairn T, Knight RT, Kenny J, Langton CM, Trapp JV (2014) A practical and theoretical definition of very small field size for radiotherapy output factor measurements. *Medical Physics*, **41**: 041707-1-8.
 31. Benmakhlof H, Sempau J and Andreo P (2014) Output correction factors for nine small field detectors in 6 MV radiation therapy photon beam: A PENELOPE Monte Carlo study. *Medical Physics*, **41**: 041711-1-12.